

301BE

elite

Mezzaluna.
Half-Moon.

INOXA
SCHEDA TECNICA - DATASHEET

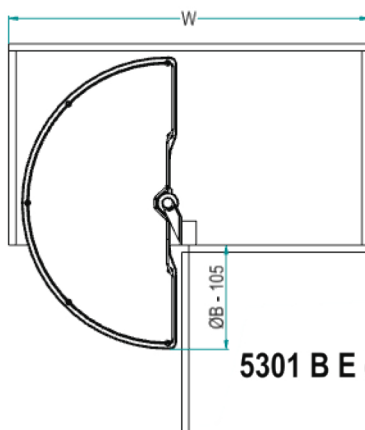
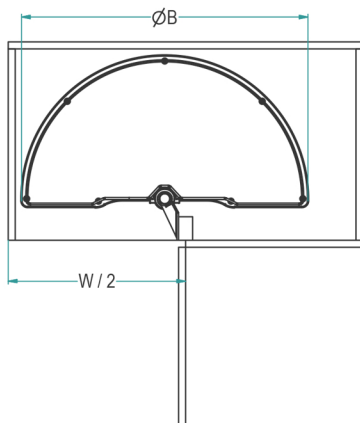

5301 B E (AS) / 66 CB

Optional AS -
Anti-scivolo
Anti-slip

Cod. -

	ØB [mm]	Misura Anta / Door Size [cm]	W min [mm]
66	635	40	800
76	745	45	900

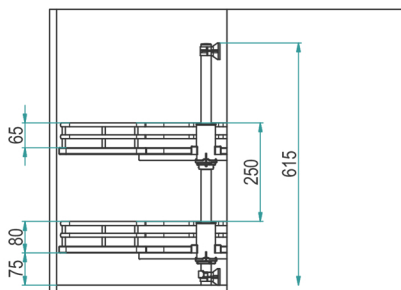

Finiture / Finishing -

Cod.	Descr.	Caratteristiche	Features
CB	"Cromo Bianco"	Cesto cromato, Fondo bianco	Chromed Basket, "White" Bottom
CG	"Cromo Grigio"	Cesto cromato, Fondo grigio	Chromed Basket, "Grey" Bottom
T	"Titanio"	Cesto nichelato nero protetto, Fondo "Ardesia"	Black nickel coated Basket, "Slate" Bottom
AR	"Ardesia" (RAL7043)	Cesto verniciato "Ardesia", Fondo "Ardesia"	"Slate" painted Basket, "Slate" Bottom
CH	"Champagne"	Cesto verniciati "Champagne", Fondo "Champagne"	"Champagne" painted Basket, "Champagne" Bottom

Soft-Close di serie / Soft-Close as standard

Trattamento antiscivolo a richiesta / Antislip treatment on demand

Portata kg 10 per piano

Loading capacity 10 kg per shelf